

Quantum Key Distribution Links between Mobile Platforms

QCRYPT 2023

Andrew Conrad¹, Samantha Isaac², Roderick Cochran³,
Daniel Sanchez-Rosales³, Timur Javid¹, Shuen Wu^{1,2},
Prof. Daniel Gauthier³, Prof. Paul Kwiat^{1,2}

¹Department of Electrical Engineering, University of Illinois Urbana-Champaign (UIUC), Urbana, IL

²Department of Physics, Illinois Quantum Information Science & Technology Center (IQUIST)
University of Illinois Urbana-Champaign (UIUC), Urbana, IL

³Department of Physics, The Ohio State University, Columbus, OH

Outline

- Motivation
- System Overview
- Results
- Next Steps

Motivation

Mobile Quantum Network

Future Quantum Internet

- Core Pillars: Secure communication, distributed sensor networks, distributed quantum computing
- Many QKD efforts are focused on fixed fibers, or very long free-space links
- Mobile Quantum Links can extend the benefits of the future quantum internet for humans on the go:
 - Drones, cars, planes, satellites, buildings, etc.
- Prior mobile QKD links:
 - satellite-to-ground [1]
 - ground-to-airplane [2]
 - airplane-to-ground [3]
 - drone-to-ground [4]
 - stationary ground-to-moving-vehicle [5]



This image was generated with the assistance of AI

[1] Liao, et al. "Satellite-relayed intercontinental quantum network." *PRL* 120.3 (2018): 030501.

[2] Pugh, et al. "Airborne demonstration of a quantum key distribution receiver payload." *Quantum Science and Technology* 2.2 (2017): 024009.

[3] Nauerth, et al. "Air to ground quantum key distribution." *Quantum Communications and Quantum Imaging X*. Vol. 8518. SPIE, 2012.

[4] Tian, et al. "Drone-based quantum key distribution." *arXiv preprint arXiv:2302.14012* (2023).

[5] Bourgoin, et al. "Free-space quantum key distribution to a moving receiver." *Opt. Exp.* 23.26 (2015): 33437.

Free-Space Quantum Network

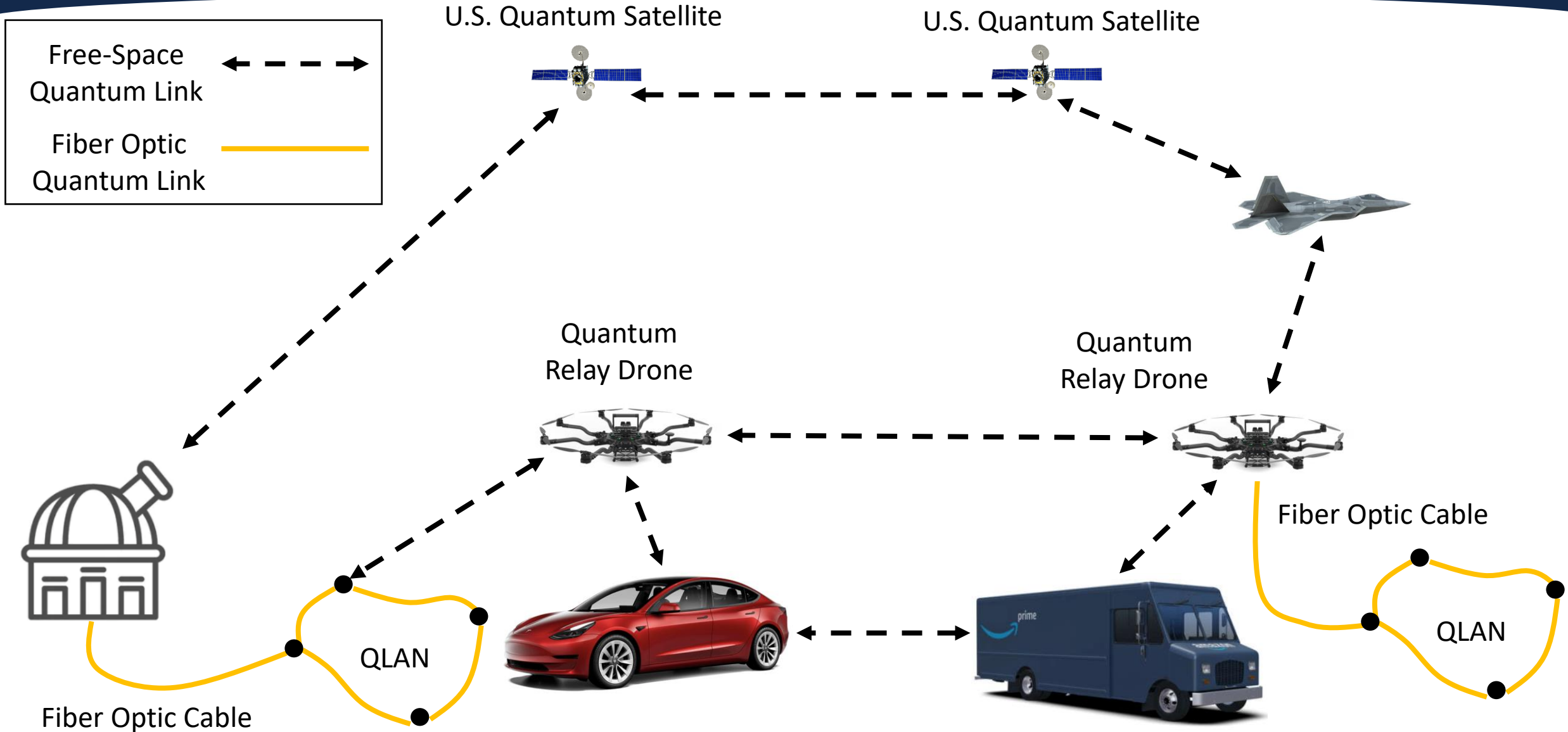

Free-Space Quantum Network

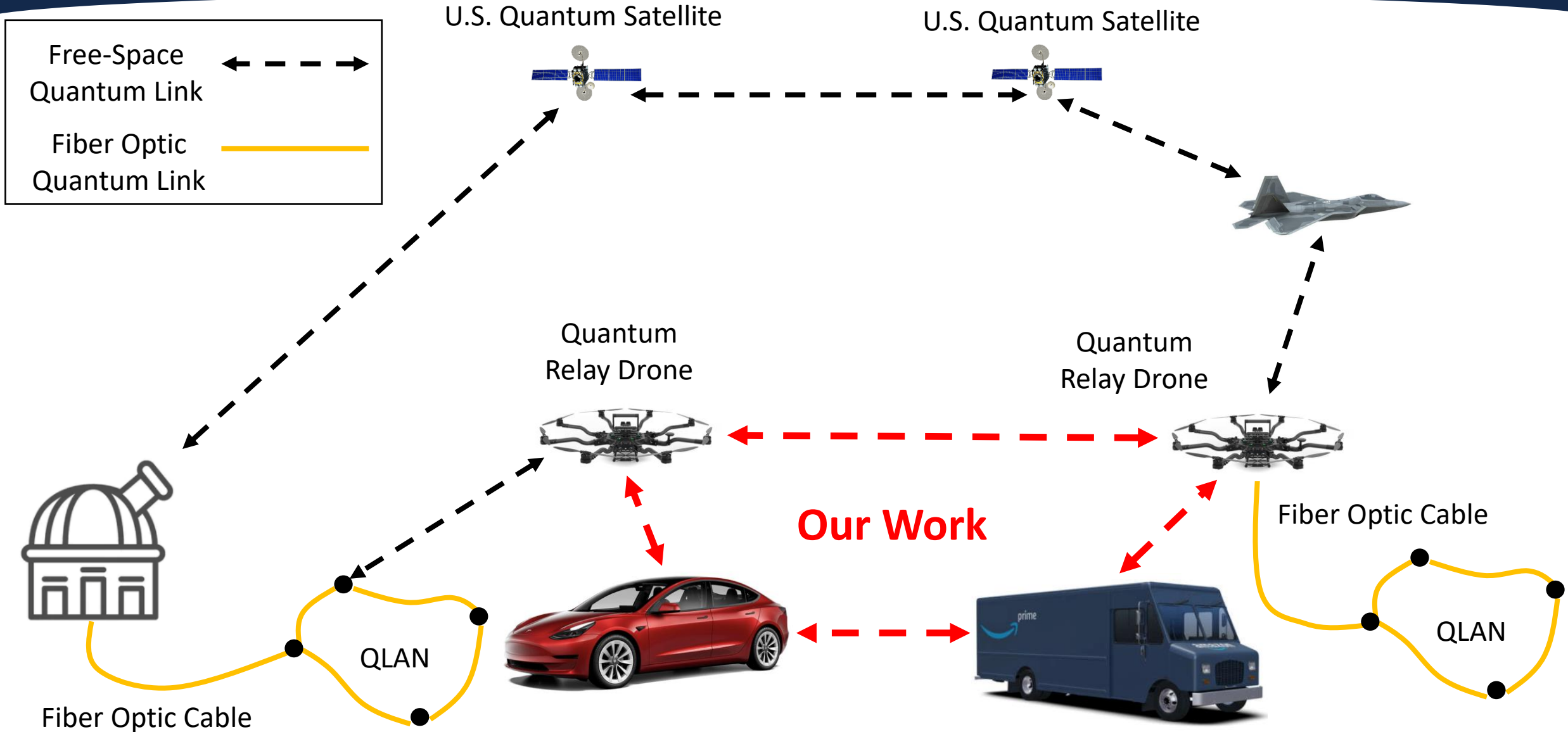

System Overview

System Design

System Overview:

- Quantum Transmitter (Alice)
 - Quantum Key Distribution (QKD) source:
 - Resonant cavity LED
 - Decoy state
 - Polarization encoded
 - Custom optics benches
- Quantum Receiver (Bob)
 - Single-Photon Detectors (SPCM-AQ4C)
 - FPGA-based Time-Tagger
 - Qubit-based Time Synchronization (Post-processing)
- Pointing, Acquisition, and Tracking (PAT) system
- Mobile Platforms:
 - Drone
 - Car

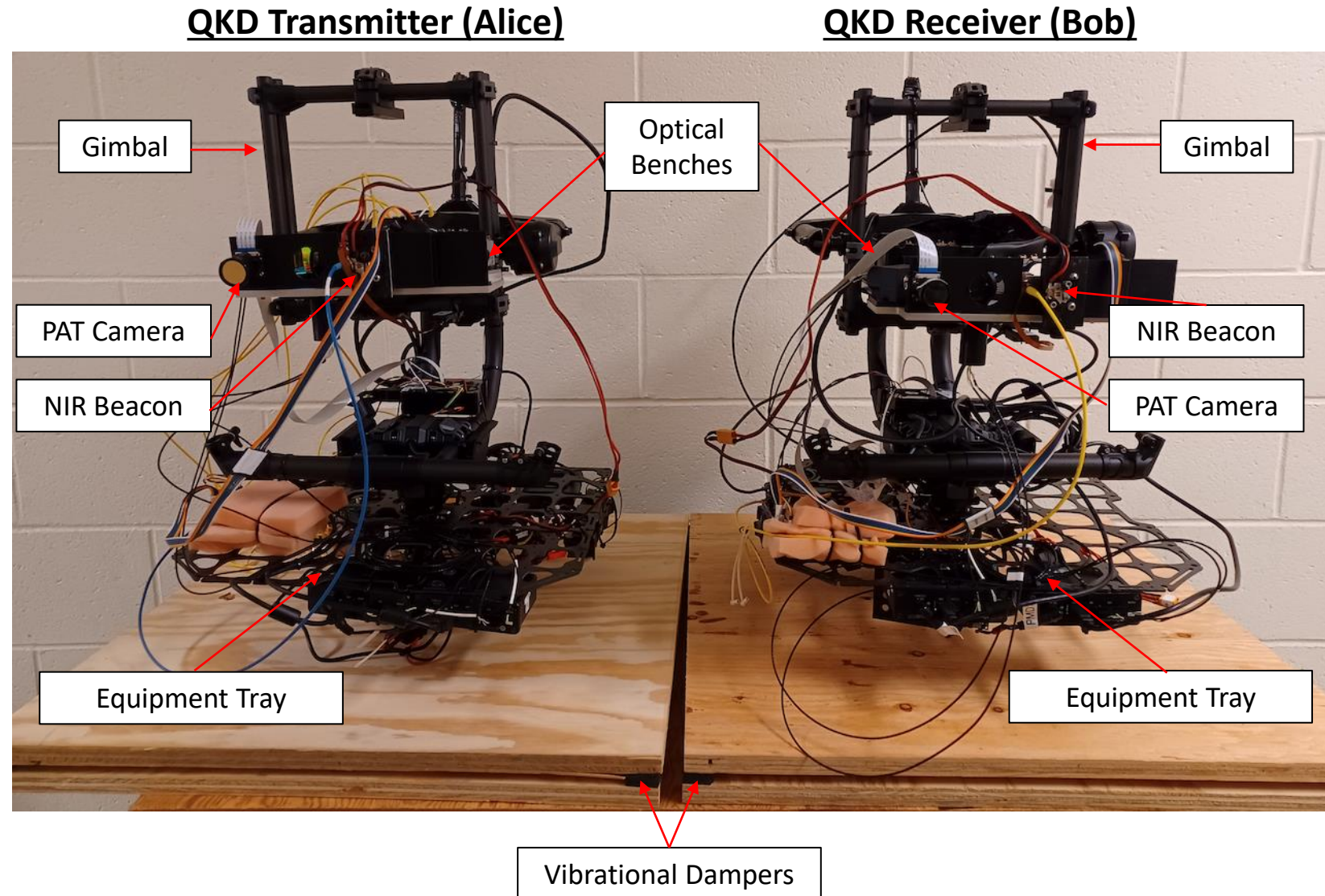

Image Courtesy Timur Javid

Modular Design

Modular Design:

- Our QKD system shares no resources with host mobile platform
 - Power
 - Control
 - Communication
- Single quick-release connection with drone
 - Place QKD transmitter (receiver) on other platforms (*e.g.*, vehicle) with no required hardware changes



QKD Source (Resonant Cavity LEDs)

- **Decoy State Quantum Key Distribution (QKD)**
- Resonant Cavity LED Source
- Encode in Polarization Degree of Freedom (DoF)
- Signal + 2 Decoy Intensities
- FPGA-based Hardware True RNG
- 3-State protocol:
 - Signal Basis - $|R\rangle/|L\rangle$
 - Error Checking - $|H\rangle$

Roithner LaserTechnik
RC650-TO46FW

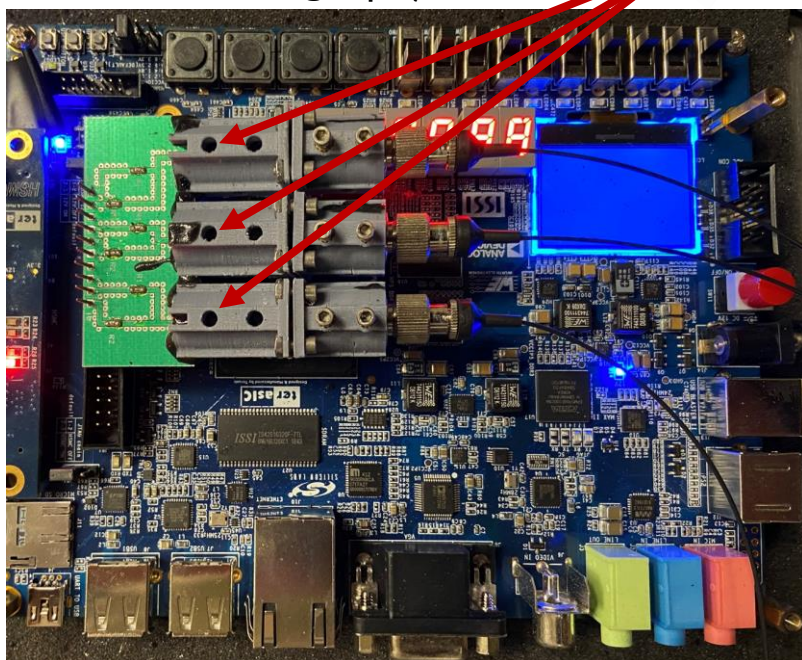

- **Spectral Overlap:** 94.6% for all states, using 1-nm narrow-band filter (Andover 656FS02-12.5)

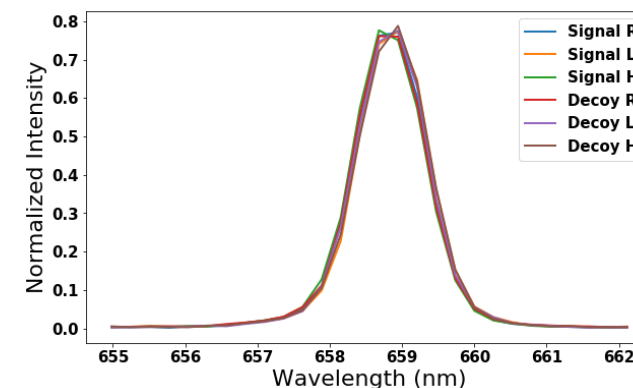

- **Temporal Overlap:** 97.1% for all states, after calibrating FPGA phase-locked loops

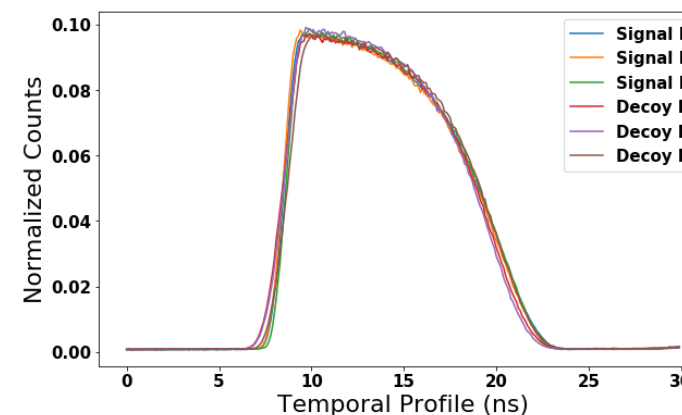

- **Spatial Overlap:** achieved using single-mode fiber (SMF)

PAT Subsystem (Course Adjustment)

Outer-Control Loop Calibration

- Initial Pointing, acquisition, and course pointing
- IR Beacon/IR Camera
- Image processing to identify location in camera's reference frame
- Feedback Control

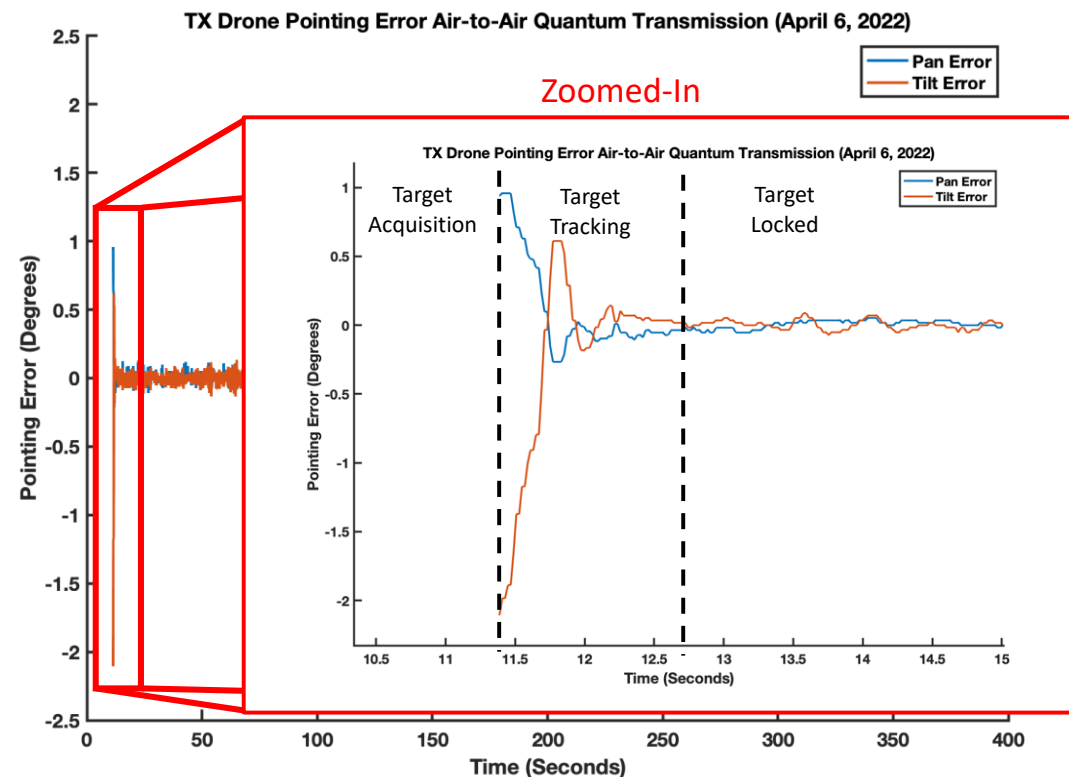
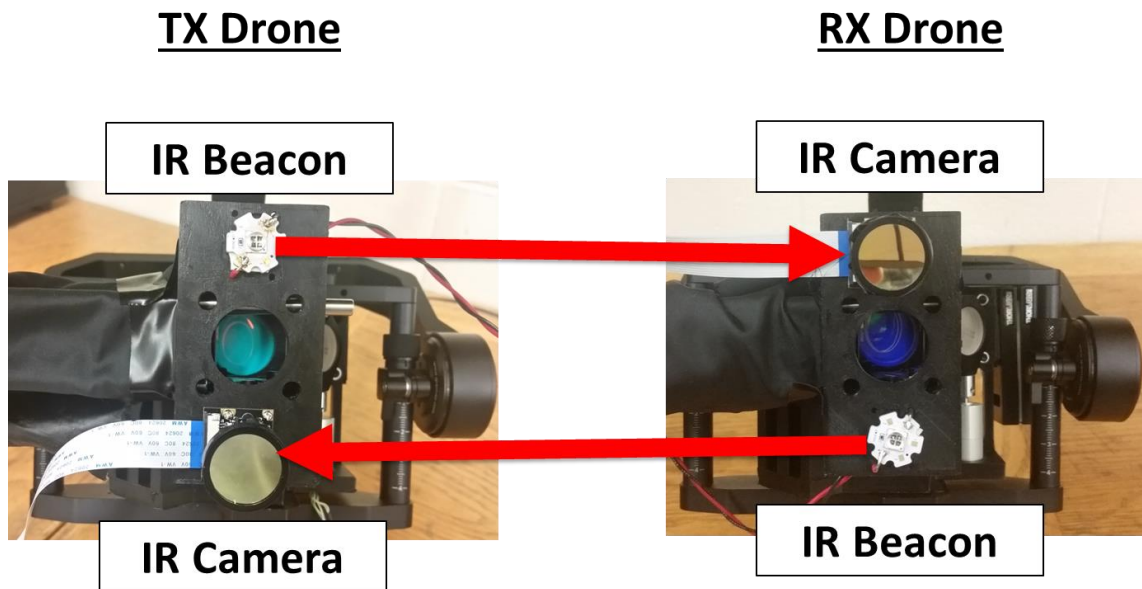

Gimbal (Movi Pro)



- Tracking Performance:
 - Pan RMS Error = 0.0230°
 - Tilt RMS Error = 0.0263°

Gimbal Jitter Specification = 0.02°

PAT Subsystem (Fine Adjustment)

PAT Subsystem (Fine Adjustment)

- Co-propagating laser beacons
 - Transmitter: 705-nm beacon
 - Receiver: 520-nm beacon
- Fast Steering Mirrors + Position Sensitive Diode (PSD)
- Senses incoming beacon beam Angle of Arrival (AoA)
- Raspberry Pi single-board computer
- Local (no PAT communication between drones)

Fast Steering Mirrors (Model LR-17)

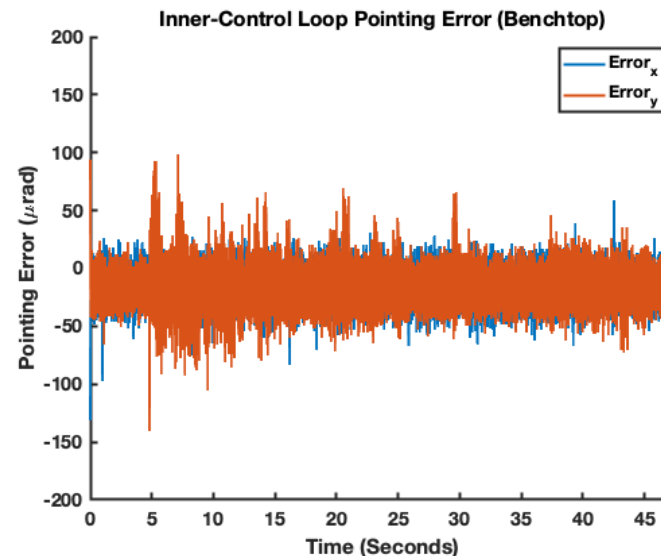
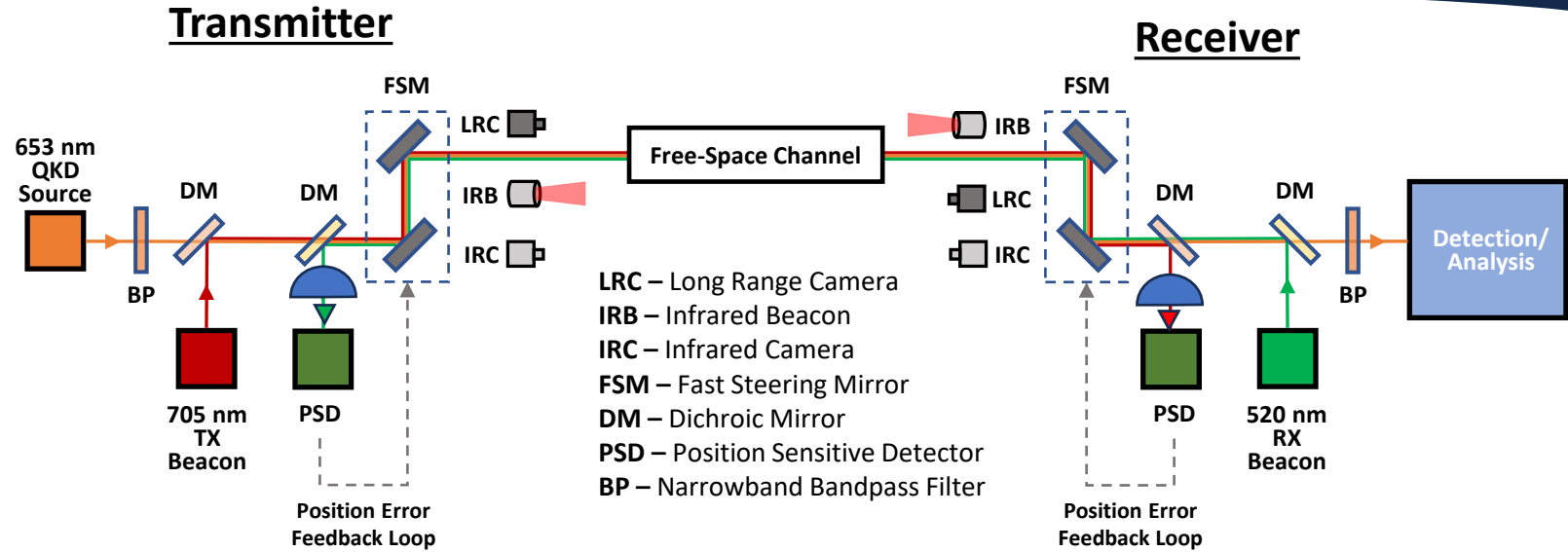

Pointing Error_x = 21.1 μrad
Pointing Error_y = 22.9 μrad

Results

Air-to-Air Classical Locking

Drone Platform

- Alta 8 Pro Drone
- 20 lbs payload capacity
- Two 10,000 mA-hr Lithium Polymer Batteries



Image Courtesy Timur Javid

System Characterization

- Classical Air-to-Air Locking into multimode fiber
- Average 2.25 dB Channel Loss (60% transmission)
- 10-meter distance

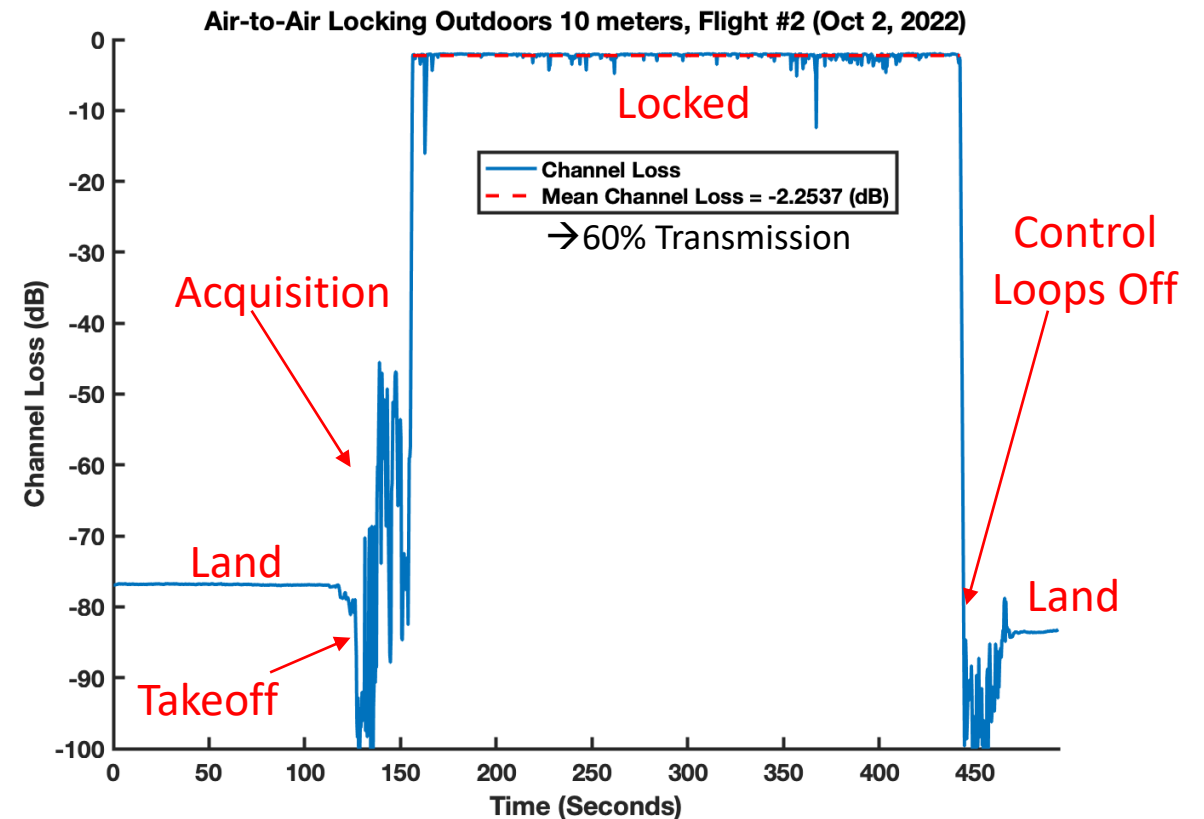

Drone Air-to-Air QKD Video



Drone Air-to-Air QKD Flights (Nov 2nd, 2022)

Air-to-Air QKD Setup

- Both drones hovering
- 10-meter distance between drones
- Altitude ~5 meters above ground

Quantum Transmission

- Average QBER = 2.9% (R/L Basis), 3.0% (H/V Basis)
- 1st demonstration of drone-to-drone QKD
- Collaborating with Lütkenhaus group to develop tailor-made finite key analysis

UNIVERSITY OF
WATERLOO



Scott, Lars



Image Courtesy Timur Javid

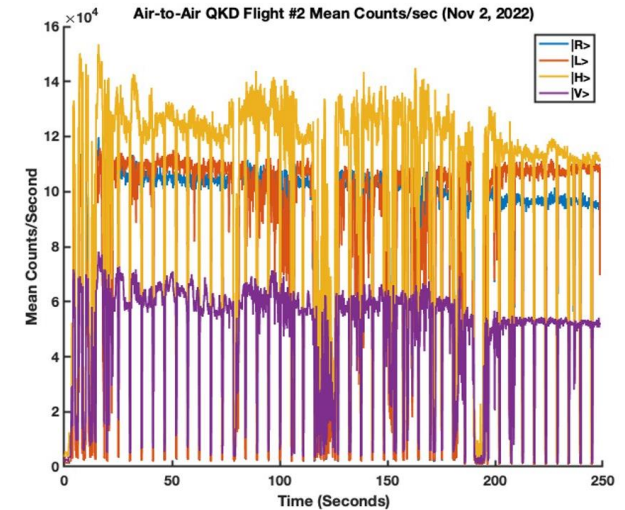
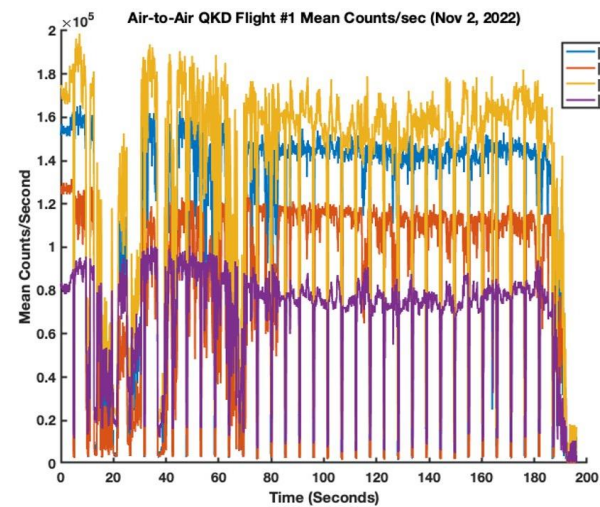

	Flight #1	Flight #2	Flight #3
QBER (R/L)	2.0%	1.8%	5.0%
QBER (H/V)	3.6%	3.1%	2.4%
Mean Photon Number μ	0.78	0.78	0.73

Drone-to-Vehicle Results

Air-to-Car Setup

- Drone flying parallel to moving car
- Speeds up to 10 mph
- Transmitter on drone, receiver on car



Image Courtesy Timur Javid

Classical Transmission

- Average coupling efficiency 38% into multimode fiber

QKD Transmission

- Average QBER = 6.4% (R/L Basis), 3.0% (H/V Basis)

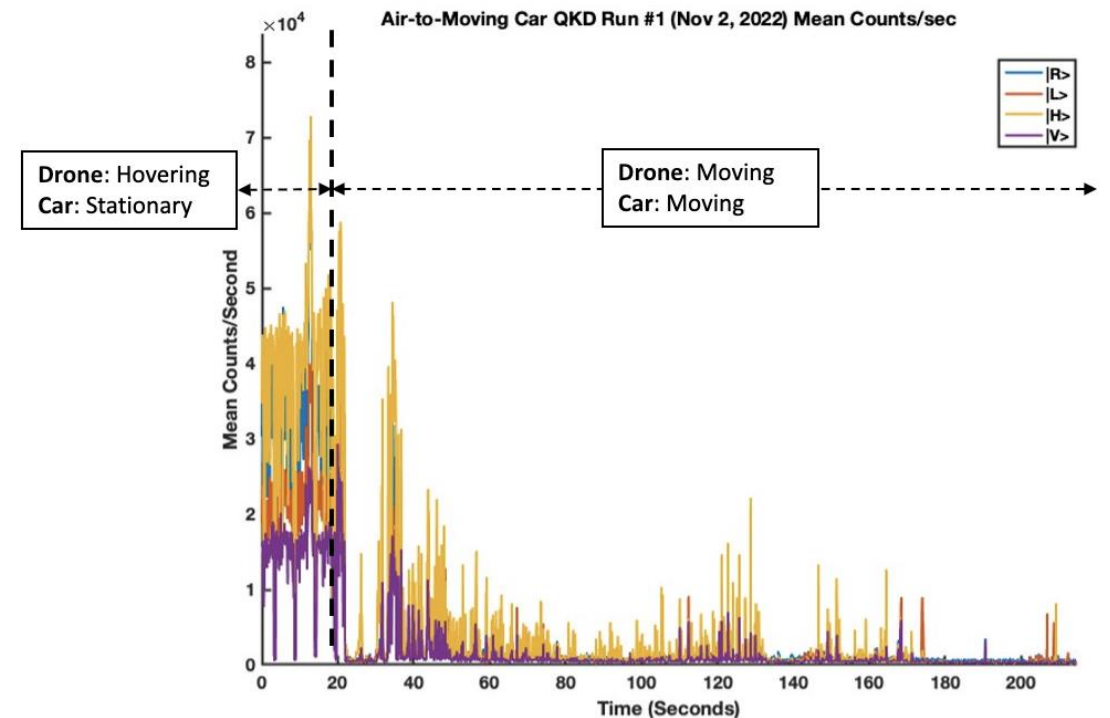

Vehicle-based Quantum Networking

Car-to-Car Setup

- Transmitter and receiver in separate cars
- Payloads are placed in car's back seat
- Speeds up to 10 mph

Transmitter



Receiver



Classical Transmission

- Average classical coupling efficiency 55% into multimode fiber

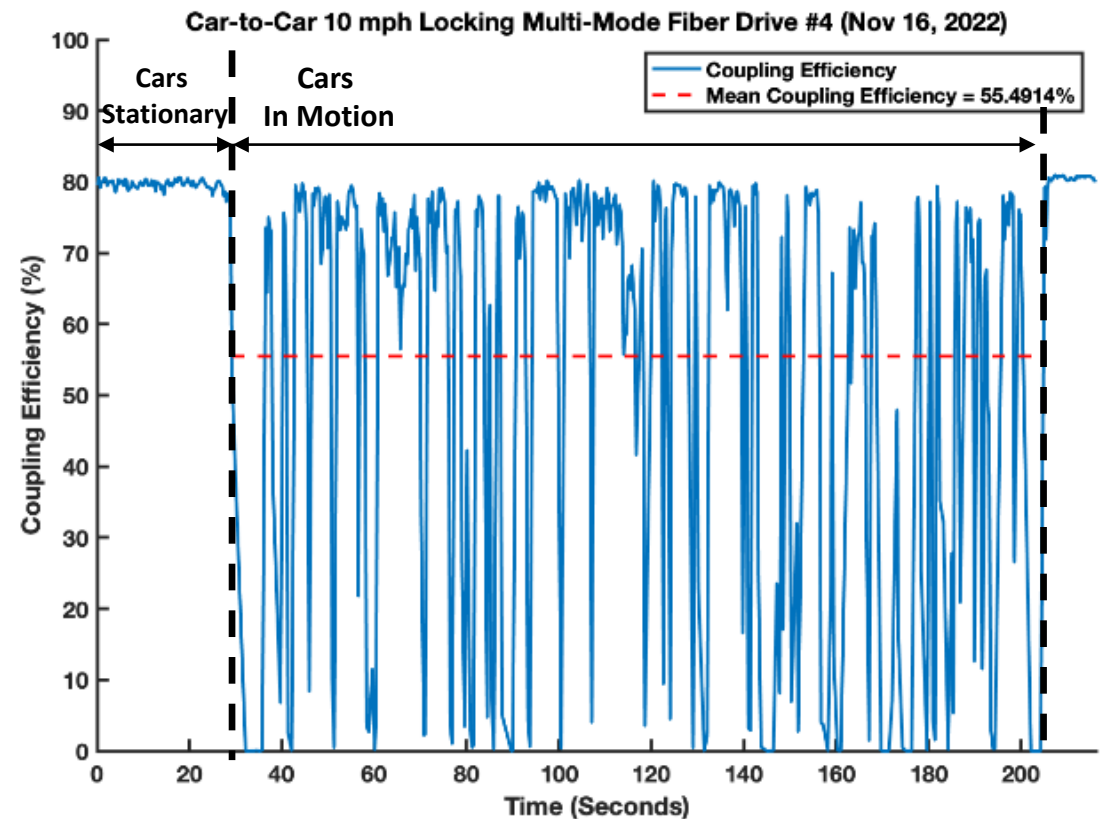

70 mph Vehicle-to-Vehicle Quantum Transmission

Car-to-Car Quantum Setup

- 70 mph
- Interstate Highway (I-57)
- Outer-Control Loop only (Near-IR Beacon)
- No alignment lasers
- Attenuated laser quantum source
- Coupled into multi-mode and single-mode fiber
- Achieved 70 mph 28.6 dB SNR into multimode fiber and 17.4 dB SNR into single-mode fiber
- **We believe this is the first demonstration of a car-to-car quantum link on public highway**



Image Courtesy Google Earth

70 mph Vehicle-to-Vehicle Quantum Transmission



70 mph Car-to-Car into Multimode Fiber

Multimode Fiber

- Mean Signal = 10,465,380 counts/sec
- Mean Background = 14,440 counts/sec
- Mean Signal-to-Noise (SNR) = 28.6 dB

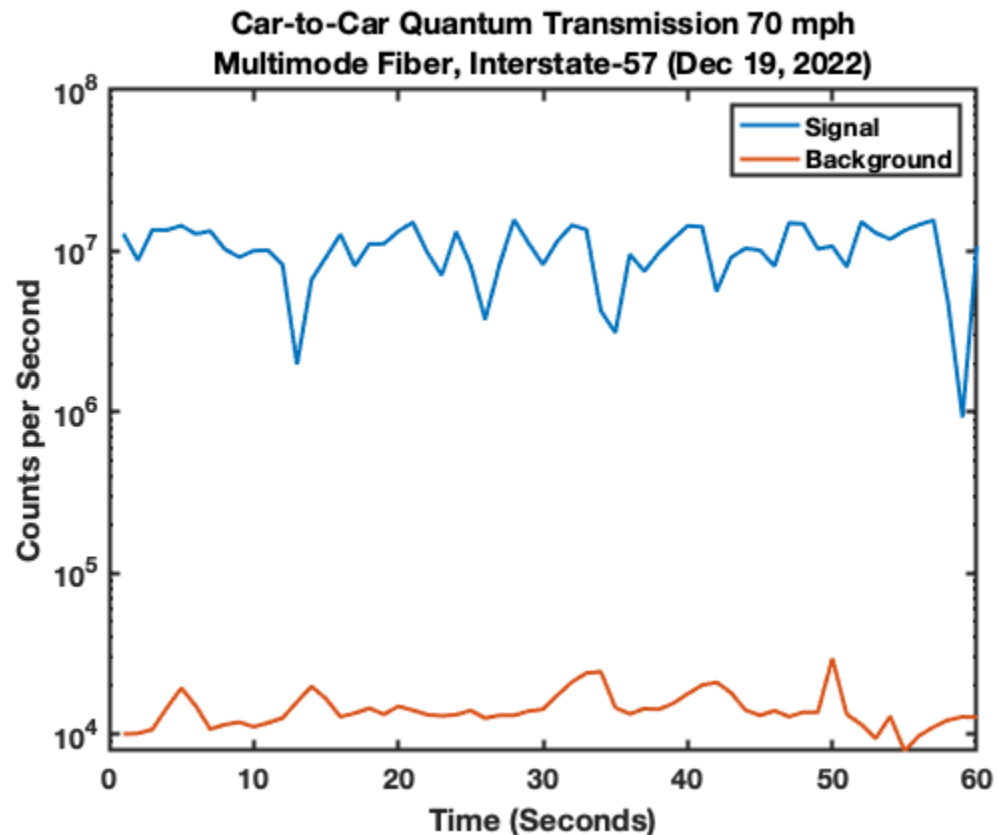

Single-Mode Fiber (SMF)

- SMF needed for quantum teleportation, entanglement swapping, etc.
- Mean Signal = 97,080 counts/sec
- Mean Background = 1,730 counts/sec
- Mean Signal-to-Noise (SNR) = 17.4 dB

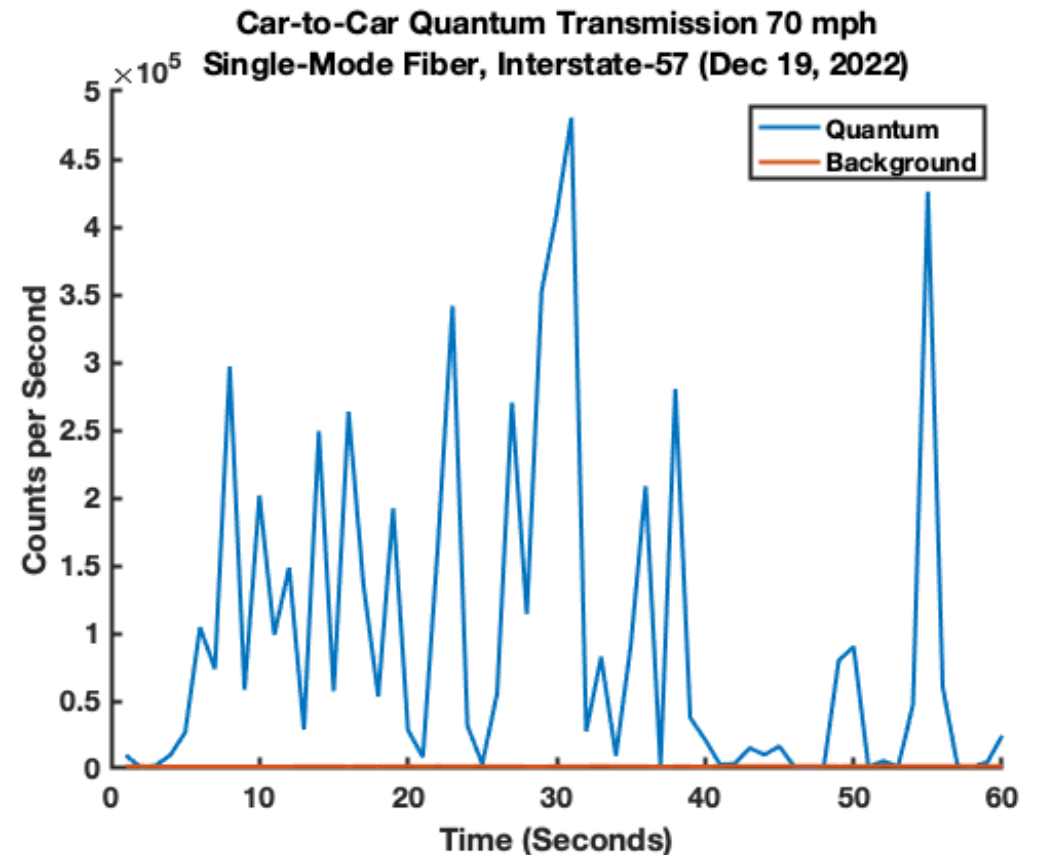

Summary

Summary

Summary

- Drone-to-Drone QKD link
 - Average QBER: 2.9% (R/L Basis), 3.0% (H/V Basis)
 - 60% mean classical coupling efficiency
 - 1st known demonstration
- Drone-to-Car QKD link
 - Average QBER = 6.4% (R/L Basis), 3.0% (H/V Basis)
 - 38% mean classical coupling efficiency
 - 1st known demonstration
- Car-to-Car Quantum link
 - 70 mph on highway
 - 28.6 dB SNR into multimode fiber
 - 17.4 dB SNR into single-mode fiber
 - 1st known demonstration

Next Steps

System Upgrades

- Increase operating distances
 - 275 meters on ground
- Night → Daytime Operation:
 - SMF coupling
 - More spectral filtering
 - Pulsed beacons

NIR Beacon as seen by PAT Gimbal Camera (275-m Distance)



Entanglement Distribution

- Distribute EPR Pair between two mobile platforms
- Requires free-space quantum link
- Building block for distributed quantum sensors

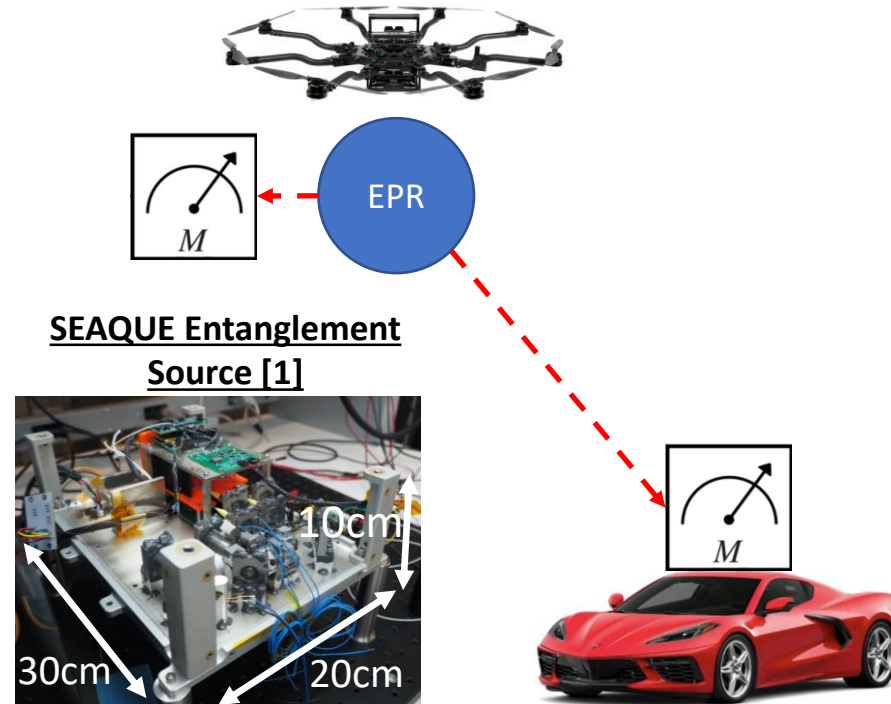

Quantum Position Verification (QPV)

- Authenticate the position of a mobile platform using Quantum Resources
- Verifiers collaborate to accept or reject the proposed position of a prover (P)
- Modulated Entanglement state: $|\psi\rangle_{AB}$

Verifier #1

Verifier #2

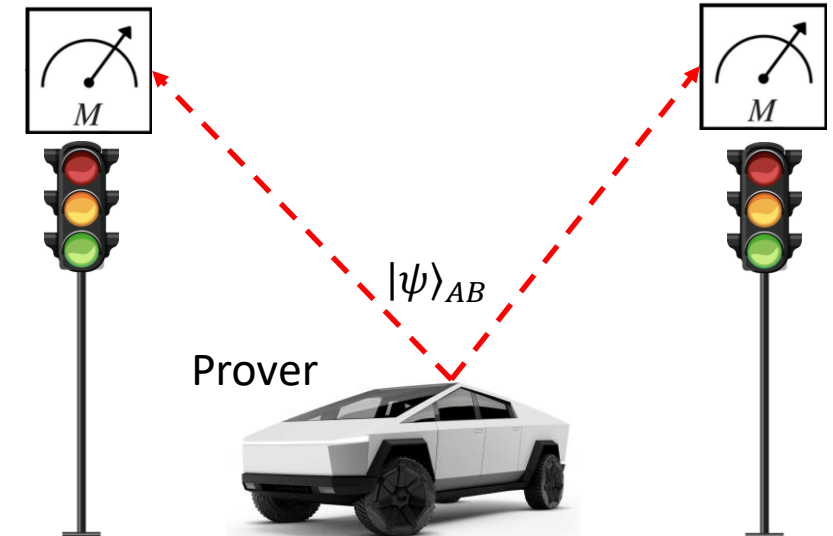

Research Team

Prof. Paul Kwiat



Prof. Daniel Gauthier



Samantha Isaac, Timur Javid, Roderick Cochran,
Daniel Sanchez-Rosales, Andrew Conrad, Shuen Wu



The Grainger College of Engineering
Illinois Center for Transportation



Questions?

aconrad5@Illinois.edu



Quantum State Tomography

Quantum State Tomography Results

$$\rho_H = \begin{pmatrix} 0.9958 + 0.0000i & -0.0155 + 0.0625i \\ -0.0155 - 0.0625i & 0.0042 - 0.0000i \end{pmatrix}$$

$$\rho_R = \begin{pmatrix} 0.4831 + 0.0000i & -0.0868 - 0.4909i \\ -0.0868 + 0.4909i & 0.5169 + 0.0000i \end{pmatrix}$$

$$\rho_L = \begin{pmatrix} 0.4646 + 0.0000i & 0.0958 + 0.4845i \\ 0.0958 - 0.4845i & 0.5354 + 0.0000i \end{pmatrix}$$

State	Purity	Purity Uncertainty	Fidelity	Fidelity Uncertainty	RMS Error
H⟩	1	+/- 1.69e-07	0.99	+/- 6.00e-6	5.59e-4
R⟩	0.99	+/- 2.34e-04	0.99	+/- 1.19e-4	1.68e-06
L⟩	0.99	+/- 3.54e-05	0.98	+/- 1.35e-5	1.27e-08

$$\text{QBER Estimate} = \frac{1}{2} \cdot (\text{trace}(\rho_L \cdot |R\rangle\langle R|) + \text{trace}(\rho_R \cdot |L\rangle\langle L|)) = 1.2\%$$

Drone-QKD Source Tomography (July 6, 2023)

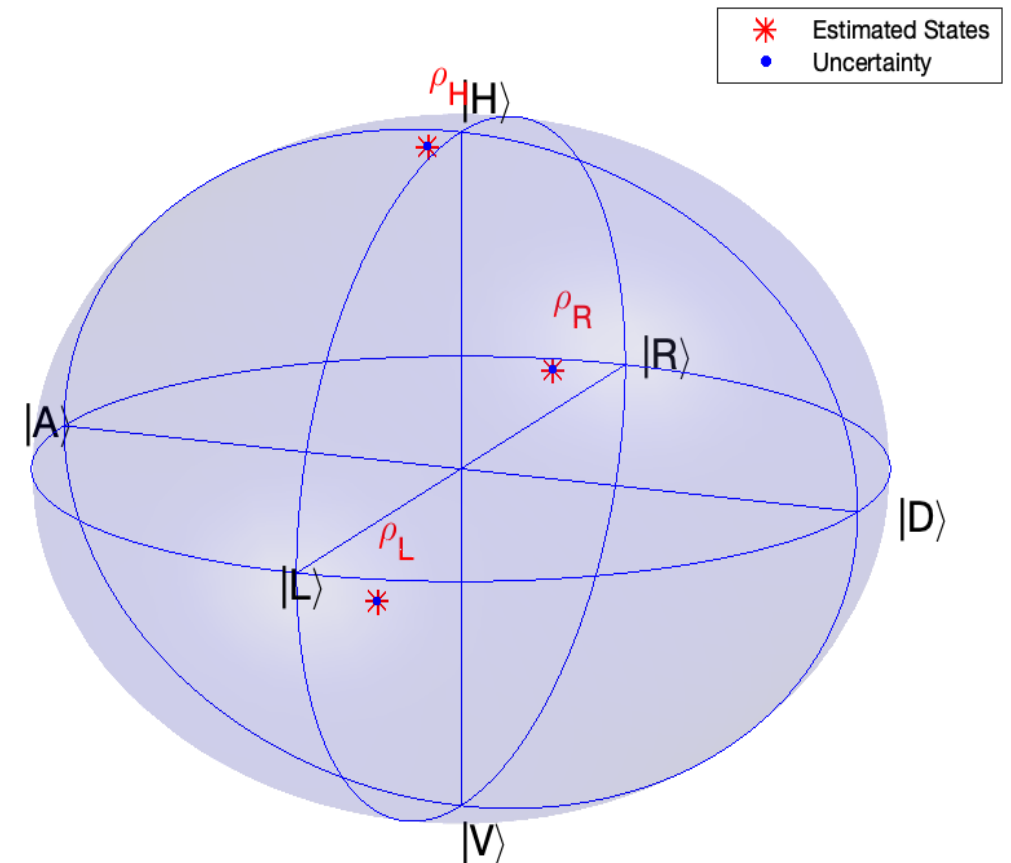

Quantum Transmitter Bench

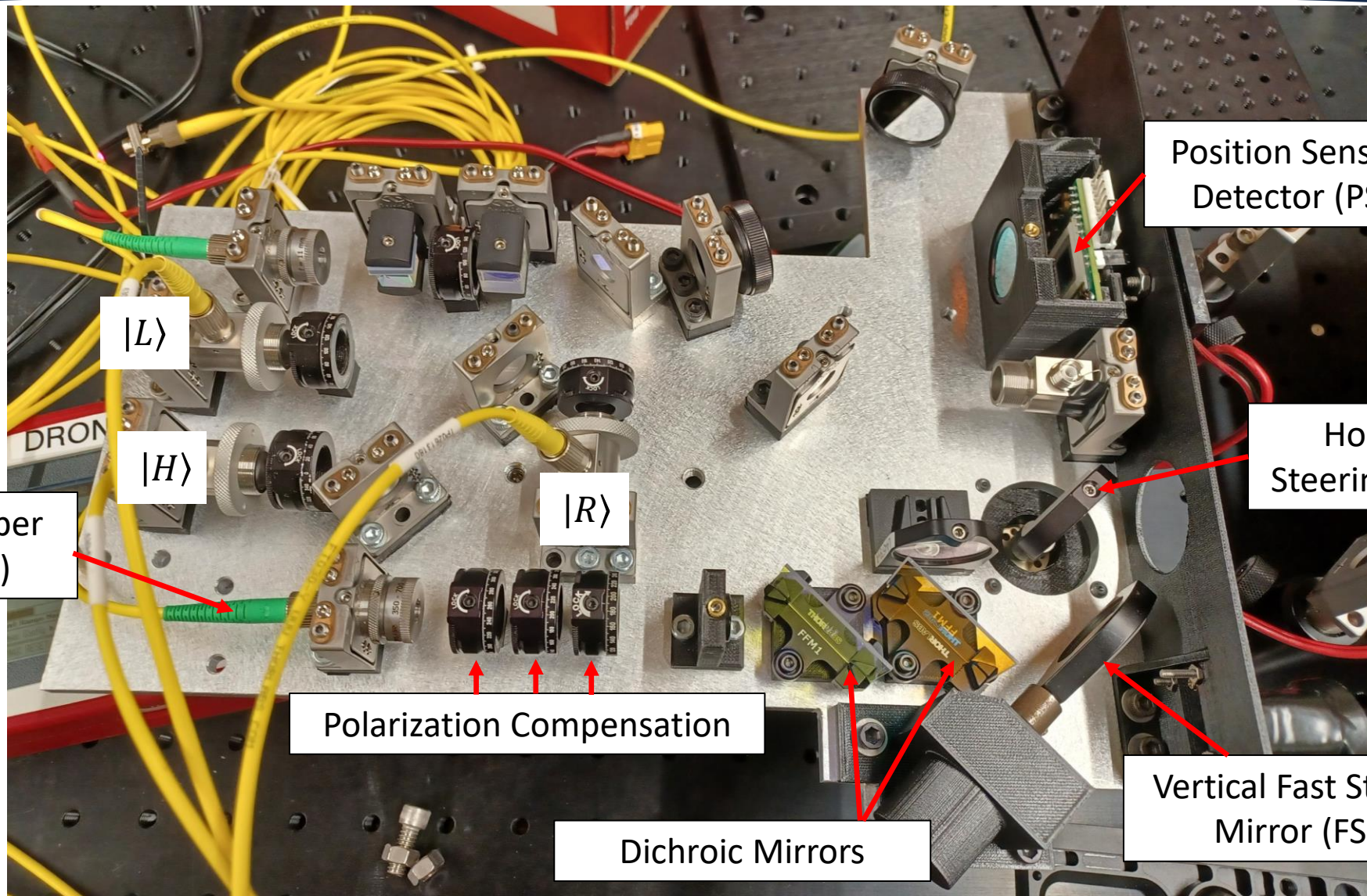

$|L\rangle$

$|H\rangle$

$|R\rangle$

Single-mode Fiber
(Spatial Filter)

Polarization Compensation

Dichroic Mirrors

Position Sensitive
Detector (PSD)

Horizontal Fast
Steering Mirror (FSM)

Vertical Fast Steering
Mirror (FSM)